

TRP-C41

User's Manual

Ethernet to Fiber Media Converter



Printed Feb. 2007 Rev 1.1

Trycom Technology Co.,Ltd
1F, No.2-11,Sihu street ,Yingge Township, Taipei, Taiwan ROC
Tel: 886-2-86781191 , Fax: 886-2-86781172
Web: www.trycom.com.tw

Copyright

Copyright Notice: The information in this manual is subject to change without prior notice in order to improve reliability, design and function and does not represent a commitment on the part of the manufacturer. No part of this manual may be reproduced, copied, or transmitted in any form without the prior written permission of manufacturer. Acknowledgment Products mentioned in this manual are mentioned for identification purpose only. Products names appearing in this manual may or may not be registered trademarks or copyright of their respective companies.

1. Introduction

TRP-C41 is a device for Ethernet extension over fiber, it supports point-to-point and networked systems. The high fiber bandwidth connections solve problems with electrical noise and different ground potentials over long transmission lines. TRP-C41 supports 10/100Base-TX transmissions up to 100 meters and 100Base-FX transmissions up to 20KM. It is the perfect solution for wide distance connections with high immunity to electrical noise.

1-1. Features

- Wide input range DC power supply.
- Plug-and-Play design for the installation within seconds.
- Compact and Rugged Metal case capable of withstanding harsh environment.
- Data rate: 10/100Mbps auto-negotiation and half-/Full-duplex mode on TX port.
- Auto MDI-X/MDI-II for 10/100Base-TX port.
- Provides media conversion from UTP to Fiber Optic media types
- Supports link fault pass through function.
- Supports far end fault function.
- LED display to indicate the whole working status.
- 3 power input types: Direct USB power, external DC adapter and screw terminal.
- Support IEEE Standard: 802.3u 100BaseTX & 100BaseFX.

1-2. Specification

- Cable: Fiber cable (62.5/125um).
- One 10/100Base-TX auto-negotiation Ethernet RJ-45 port.
- One 100Mbps fiber port with Single-mode SC connector.
- Built in 128Kb RAM for data buffer.
- Wavelength: 1310 nM.
- Fiber Power:-15 ~ -8 dBm.
- LED indicator: Power and power and TX and fiber link/activity, full/half, 10/100MB.
- Distance : 20KM can be up to 60KM (option).
- Speed : Auto 10/100MB.
- Power Consumption: 12V/160mA.
- Power requirement: USB port power or DC input or screw terminal from +10 to 30V.
- Operating temperature : 0 to 55°C .
- Storage temperature: -20 to 70°C .
- Humidity: 10-90% Non-condensing.
- Dimension: 151mm X 75mm X 26mm.
- Weight: 400g.

2. Hardware description

2-1. TRP-C41 panel layout

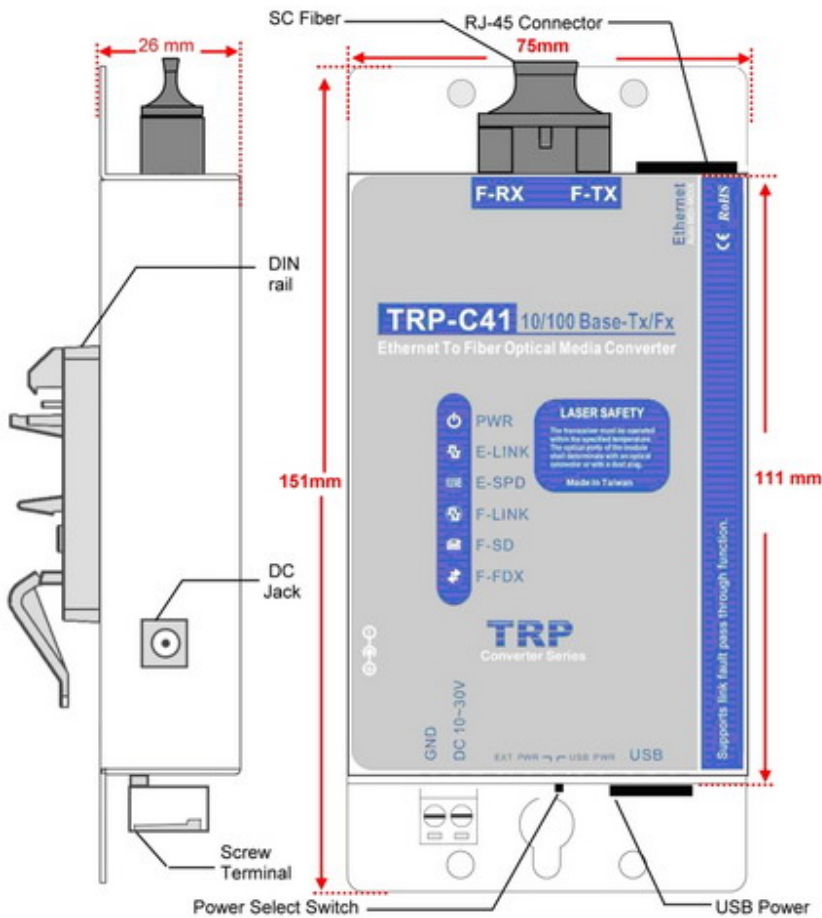

2-2. Block Diagram

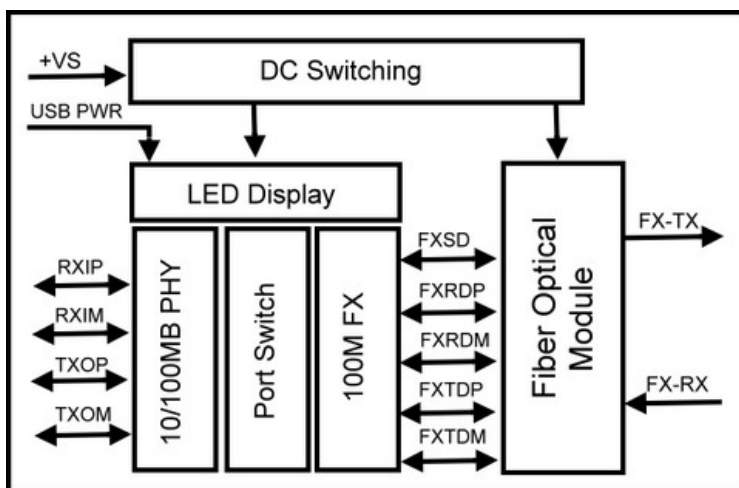

2-3. LED Display

PWR-: Power LED.

E-LINK LED: Ethernet Connection.

E-SPD LED: Ethernet 100MB.

F-Link LED: Fiber Connection.

F-SD LED: Fiber cable detect.

F-FDX LED: Fiber Active.

DC Jack: Input from +10V to +30V (it is recommended to use the 5.5*2.1*12mm DC JACK).

3. Install TRP-C41

3-1. Power input type

The TRP-C41 has three power input types, power can be supplied from

1. 2-pin screw terminal block
2. External DC plug
3. USB port.

TRP-C41 supports wide input range DC power supply from +10V~+30V. When the power is properly supplied the PWR LED will lighting to indicate the system is up. **User can only choose one of the three power sources, do not connect different power source simultaneously.**

3-2. Select power source

User may select the power source by power select switch. The method is as below.

1. Find the power select switch located at the right side of 2-pin screw terminal block.

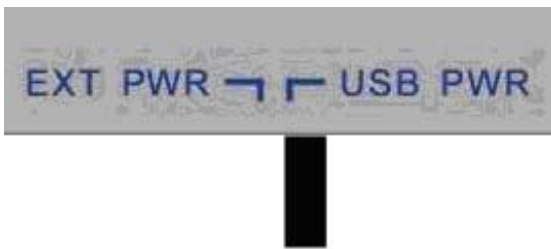

2. Move the switch to “USB PWR” to enable USB power input, and disable screw terminal and external DC adapter. User may input power from USB port by USB A/B cable.
3. Move the switch to “EXT PWR” to disable USB power input, and enable screw terminal and external DC adapter, user may input power from either screw terminal block or DC adapter.

3-3. Ethernet Connection

TRP-C41 support auto MDI/MDIX RJ-45 cable that mean user may use a straight-through or crossover cable connection between TRP-C41 and Ethernet hub, switch, or wall plate. And also can link directly to the NIC (Network Interface Card) on a PC or laptop. If the cable is properly connected the “E-LINK” LED will light up.

3-4. Fiber connection

TRP-C41 has a 100Mbps fiber port with single mode SC fiber connector, user may use standard 62.5/125um, 1310 nM wavelength fiber cable for TX and RX connection, when fiber cable is connected the F-Link, F-SD and F-FDX LED will light up.

4. Getting Start

1. Connect power source with TRP-C41.
2. Connect TRP-C41 with LAN port (Ethernet Hub or Switch) by RJ45 LAN cable.
3. Connect TRP-C41 with SC Fiber RX and TX cable

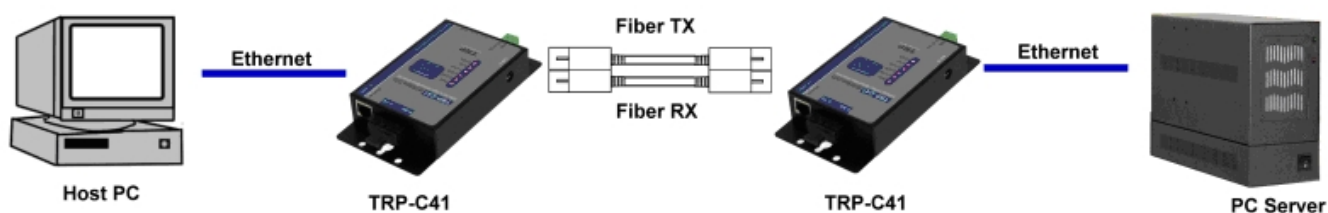

ATTENTION

This is Class 1 Laser/LED product. To avoid causing serious damage to your eyes. do not stare directly into the Laser Beam.